

Imagine the possibilities™



WDK Guideline 2000

Assessment of Rubber to Metal Bonding Agents for **NVH** applications



ACCELERATING VALUE CREATION

Executive Summary:

The evaluation of Bonding Agents to manufacture Rubber to Metal Parts for Antivibration has always been a matter of how to determine the performance and suitability for the associated requirements.

The goal of this presentation is to introduce an effort taken in the European countries, initiated in Germany, to develop a Guideline how to approach this issue and provide a benchmarking tool to the industry to find an answer to this question.

This presentation will give a short overview what has been standardized and commonly used in this industry so far and introduce the basics of the

"wdk* 2000 Guideline"

Assessment of adhesives used for rubber bonded applications in engine compartments and suspension applications

* wdk: Association of German Rubber manufacturing Industry



ACCELERATING VALUE CREATION

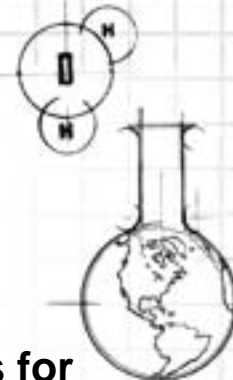

imagine the possibilities™

Outline

- **Bond evaluation**
 - The Principles
 - Established Standards => ASTM D429 Methods
 - Customized Testing => R&H's "Flexibility Test"
 - WDK Guideline 2000 for NVH applications
- **Bond performance established by WDK Guideline 2000**
 - Rubber Compounds defined for NVH assessment
 - Test Matrix / Requirements
 - Pictures / overview

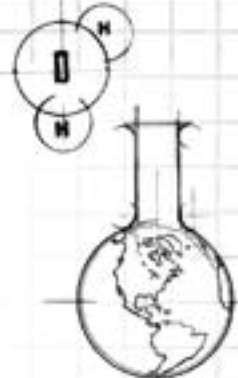

imagine the possibilities™

Evaluating Bond Performance - 1

Principles

- **Adhesion and Bonding evaluation:**
 - Tensile Strength
 - Peel strength
 - Shear Strength
 - Test pieces shape
- **Influences on static and dynamic test results:**
 - Size and shape of components
 - Exposed load conditions
 - Method of testing

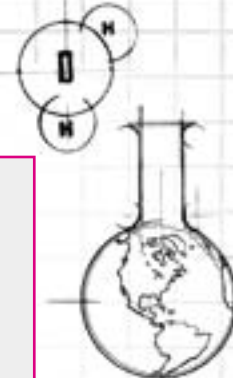

Evaluating Bond Performance - 2 Principles

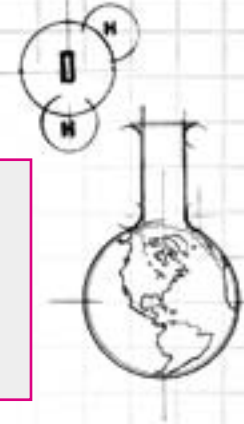

imagine the possibilities™

- **Test methods => in lab scale under standardized conditions**
- **No standard test available (ASTM, DIN,...)**
 - ⇒ Evaluation of actual parts
 - ⇒ customized tests to simulate failures similar to production parts
- **ASTM D429 Method A - D**
 - ⇒ simulate forces applied in antivibration (NVH) parts

Evaluating Bond Performance - 3

ASTM D429 Method A

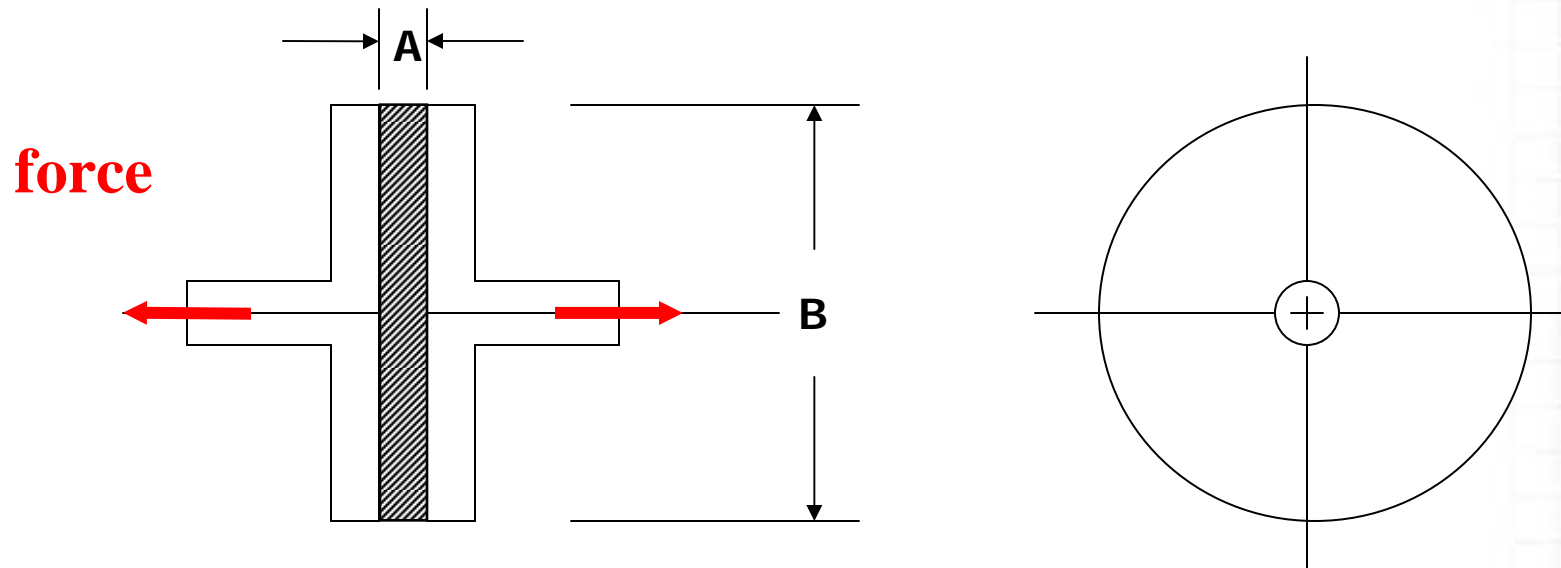

A 3.0 mm ⇔ 0.118 in
B 40.5 mm ⇔ 1.596 in

Evaluating Bond Performance - 4 ASTM D429 - B

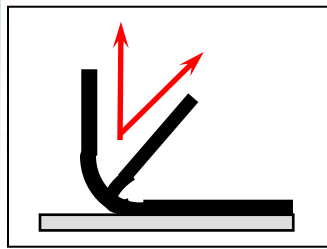
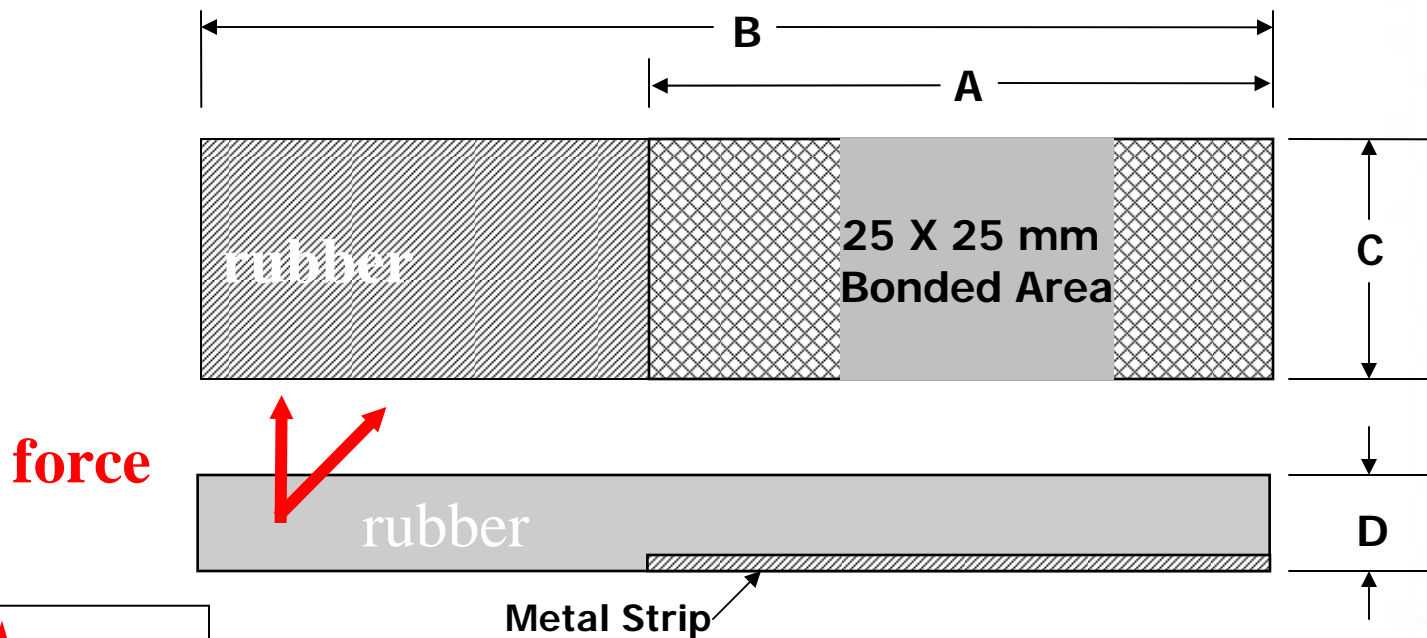

A	60.5 mm	⇔	2.38 in
B	127 mm	⇔	5.0 in
C	25.0 mm	⇔	1.0 in
D	7.9 mm	⇔	0.31 in

Evaluating Bond Performance - 5 ASTM D429 Method C (Conical)



Failure occurs at the tip

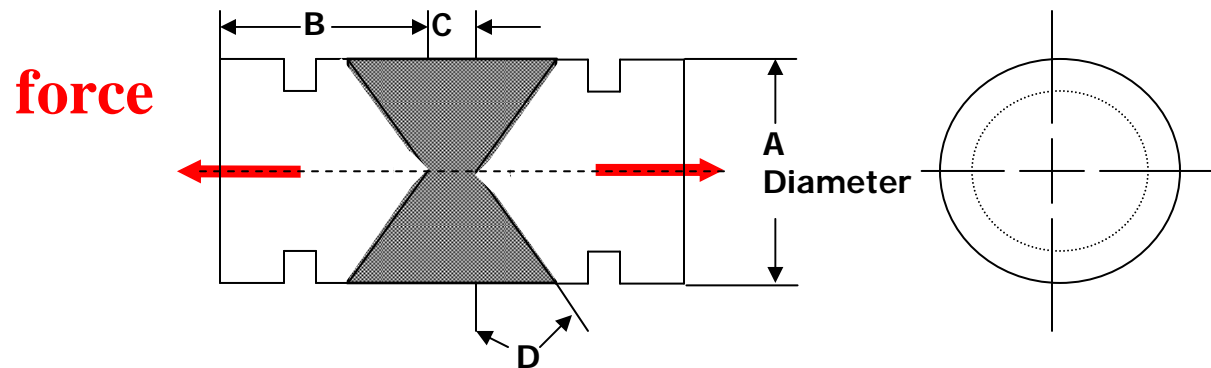

A	25.0 mm	⇔	1.0 in
B	23.5 mm	⇔	0.92 in
C	11.5 mm	⇔	0.45 in
D	45°		

Evaluating Bond Performance - 6 related ASTM D429 Method D

Also used to evaluate PV bonding
Inner disc is cured rubber

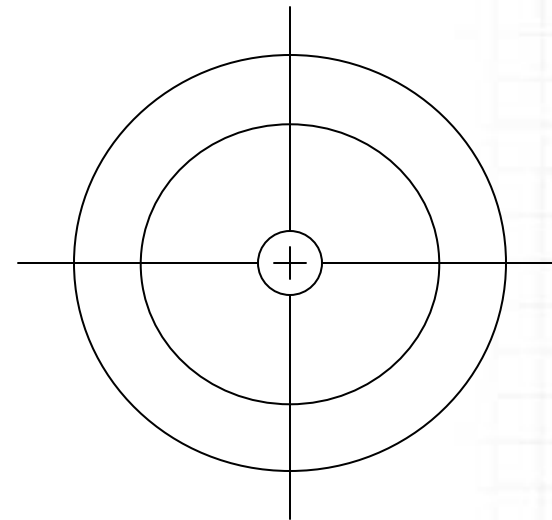
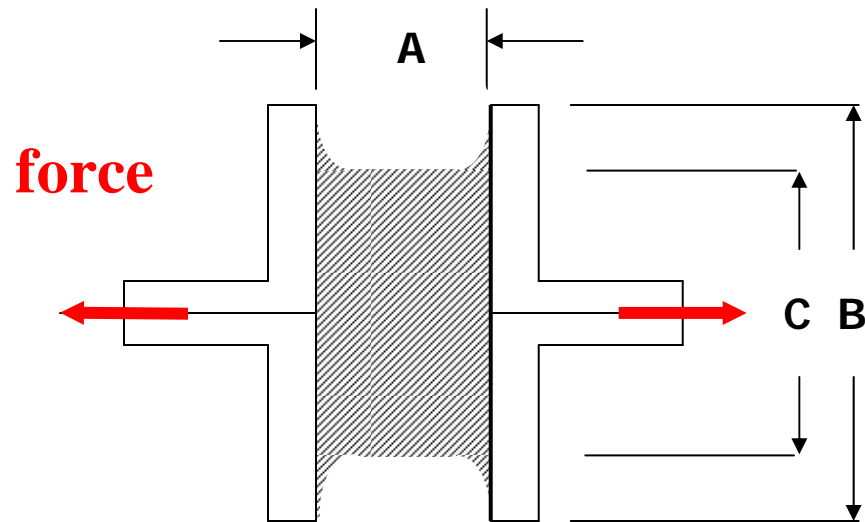

A	14 mm	↔	0.551 in
B	38 mm	↔	1.496 in
C	30 mm	↔	1.181 in

Evaluating Bond Performance - 7 ASTM D429 Method F

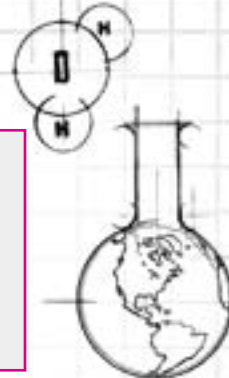

imagine the possibilities™

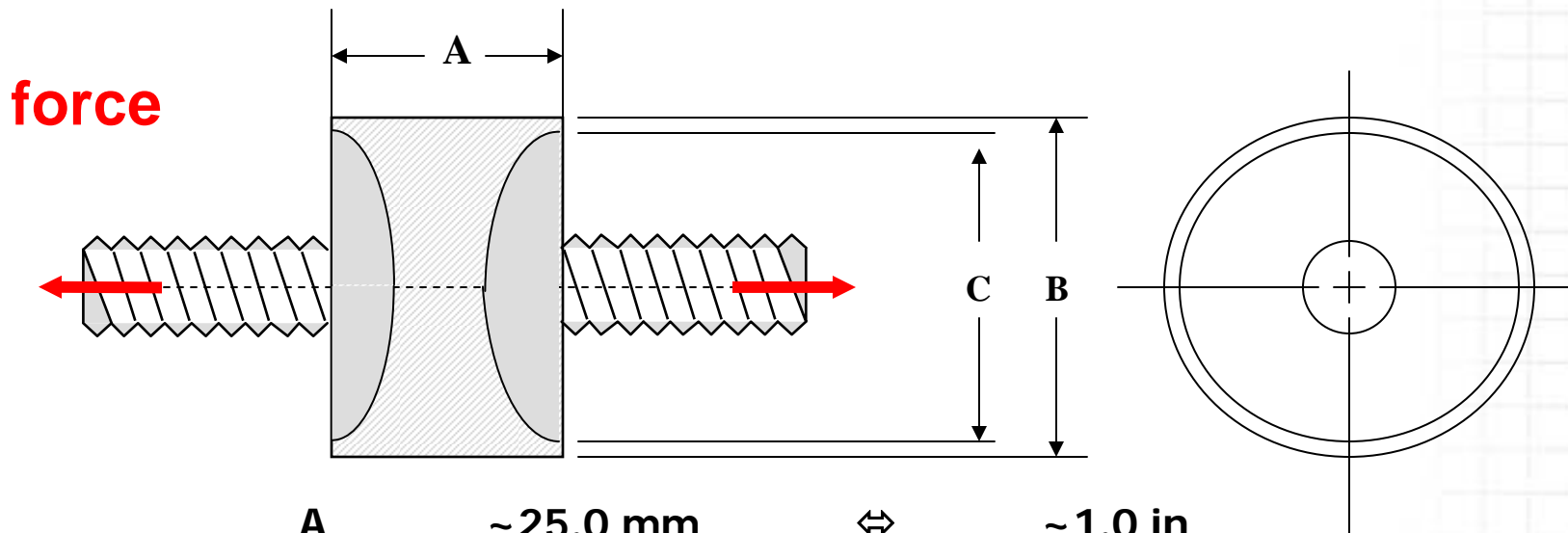

A	~25.0 mm	↔	~1.0 in
B	~28.7 mm	↔	~1.13 in
C	~20.0 mm	↔	~0.787 in

Radius of Bonding Surface 41.3 mm 1.63 in

Evaluating Bond Performance - 8

WDK* Guideline for NVH Applications

* WDK: Association of German Rubber manufacturing Industry

- **Developed by study group "Adhesives"**
 - Bonding Agent Manufacturers
 - Parts Manufacturers
 - **In Agreement with OEM's in Germany**

- **Design test procedure for:**
 - New Bonding Agents
 - Metallic or Non-Metallic substrates
 - In Areas near the Engine
 - In Suspension Applications

- **Referencing:**
 - ASTM D 429 (2003-00-00)
 - DIN 53504 (1994-05-00)
 - DIN 50011 (1982-03-00)-(environmental testing equipment)

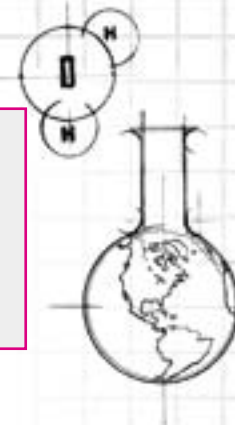

Evaluating Bond Performance – 8a

Test part design

WDK* Guideline for NVH Applications

* WDK: Association of German Rubber manufacturing Industry

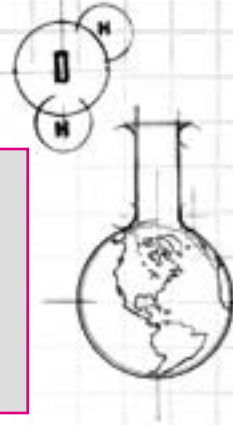

imagine the possibilities™

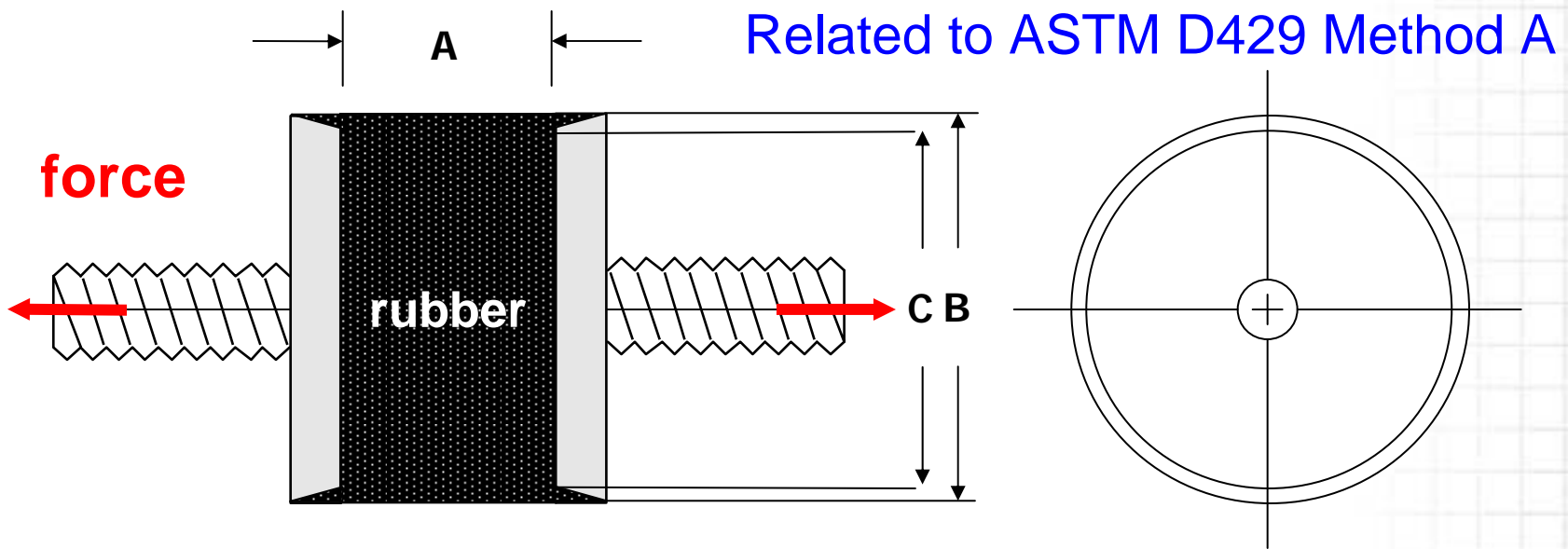

- A 20.0 mm ⇔ 0.787 in
- B 24.0 mm ⇔ 0.984 in
- C 23.2 mm ⇔ 0.913 in

Evaluating Bond Performance – 8b

The Rubber Compounds

WDK* Guideline for NVH Applications

* WDK: Association of German Rubber manufacturing Industry

- **Defined "worst case" scenarios:**

- **NR-40-G**

- Typical NR used for engine mounts

- **NR-60-H**

- Typical medium hardness NR used for suspension parts

- **NR/BR-70-G**

- Typical hard NR/BR used for suspension parts (bushings)

For detailed recipes please refer to official document:

- "Assessment of adhesives used for rubber bonded applications in engine compartments and suspension applications"
wdk 2000 – January 2007

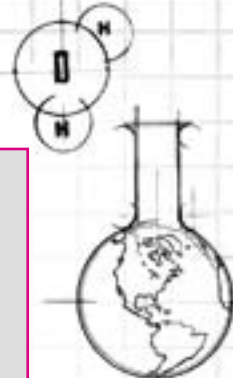

Evaluating Bond Performance – 8b

The Rubber Compounds

WDK* Guideline for NVH Applications

* WDK: Association of German Rubber manufacturing Industry

Cure Kinetics	Semi-Ev	High S8	Semi-Ev
Properties	Rubber formulation		
	NR-40-G	NR-60-H	NR/BR-70-G
Strength in MPa	24	22	16
Elongation in %	650	500	400
Module 100 % in MPa	1.1	2.3	4.8
hardness in Shore A	42	59	70
density in g/cm ³	1.04	1.10	1.17

Typical formulation properties

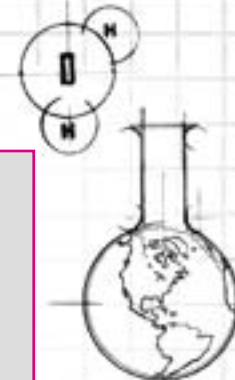

Evaluating Bond Performance – 8c Testing and Requirements WDK* Guideline for NVH Applications

* WDK: Association of German Rubber manufacturing Industry

➤ Initial and General Bond Strength after Exposure:

- NR-40-G => min 5MPa / min 85%R
- NR-60-H => min 5MPa / min 85%R
- NR/BR-70-G => min 6MPa / min 85%R

➤ Steam Resistance:

- Pre-stressed 20% for NR-40-G and NR-60-H
- Pre-stressed 15% for NR/BR-70-G
- Stored for 24h @ 95C/203F in steam phase
- Removed, cooled to RT and pulled after ≥ 16 h

➤ Pre-bake Resistance:

- Pre-heat for 5 min @ 160C/320F
- Test according to Steam Resistance

➤ Heat Resistance

- Pre-stressed 20% for NR-40-G and NR-60-H
- Pre-stressed 15% for NR/BR-70-G
- Stored for 168h @ 100C/212F
- Removed, cooled to RT and pulled after ≥ 16 h

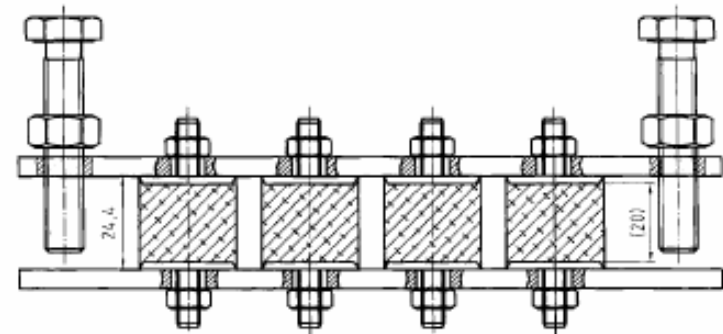

Example of a stress fixture

Evaluating Bond Performance - 9 RESULTS

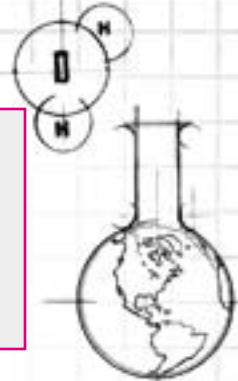

Destructive Test - Pull Test

- According to DIN 53504, ASTM D 429
- 100 mm/min
- % results are rounded up of mean value to nearest full unit

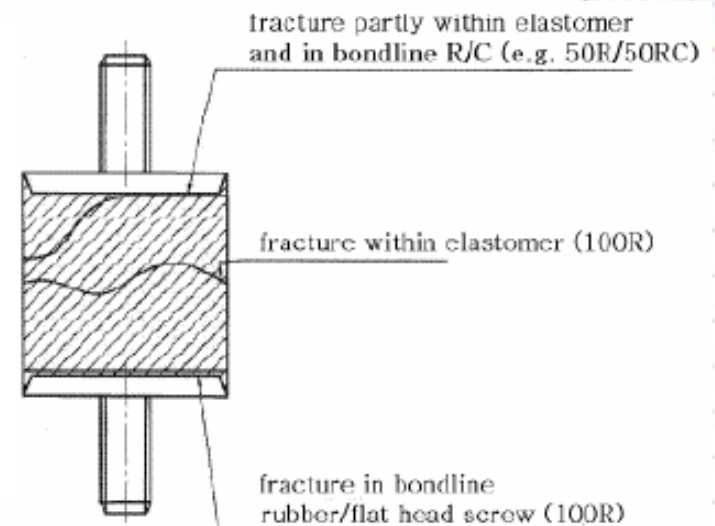

- **% rubber** => part covered by rubber after tear
- **Lbs/inch² (Mpa)** => max pull force to induce failure
- **% metal / % "RC" / %PC** => type of failure(s)

Evaluating Bond Performance – 8c Environment

WDK* Guideline for NVH Applications

* WDK: Association of German Rubber manufacturing Industry

- **Developed by study group "Adhesives"**
 - Bonding Agent Manufacturers
 - Parts Manufacturers
 - **In Agreement with OEM's in Germany**

Instituted in Germany since 2006

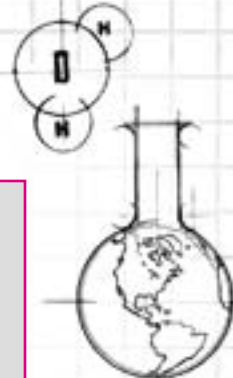

imagine the possibilities™